

- 01_COVER_PAGE
- 02_BLOCK DIAGRAM
- 03_SMARC MXM3 Connector
- 04_VIN, SMART Charger & VDD_MOD
- 05_+V1.8, +V3.3
- 06_+V5, +V12
- 07_HDMI, DP
- 08_LVDS
- 09_Camera
- 10_PCIE
- 11_LAN
- 12_USB
- 13_SATA, SD and EEPROM
- 14_I2S, HDA and buzzer
- 15_UART, CAN
- 16_GPIO, I2C, SPI
- 17_MISC, Button
- 18_HISTORY

		
Title 01_COVER_PAGE		
Size B	Document Number	Rev 00B0
Date: Friday, December 11, 2020		Sheet 1 of 18

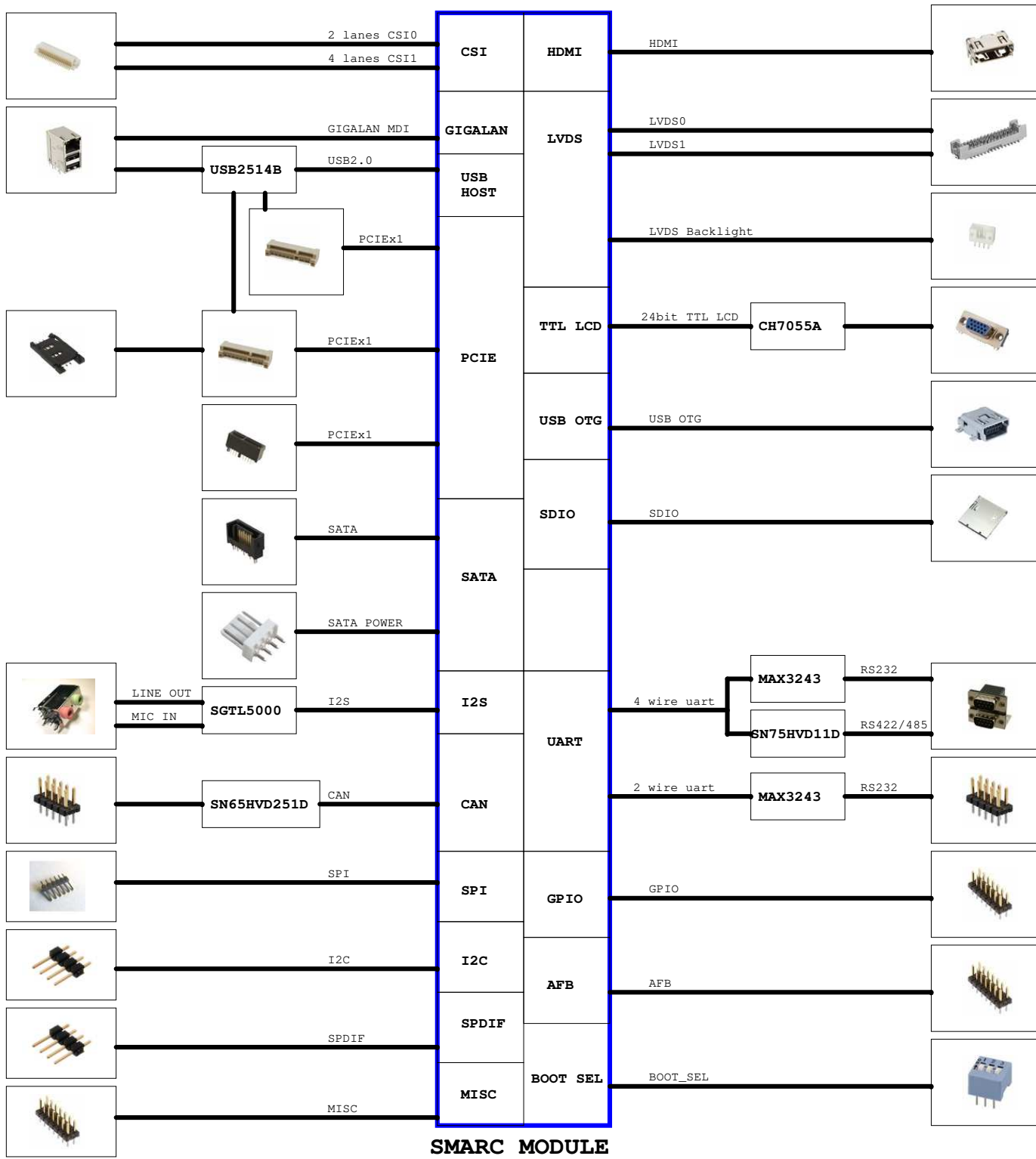

SMARC MODULE

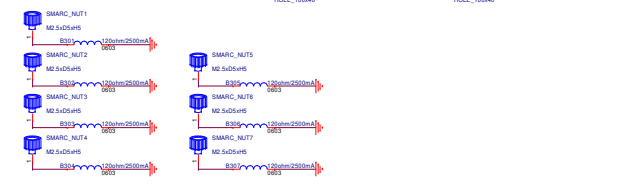
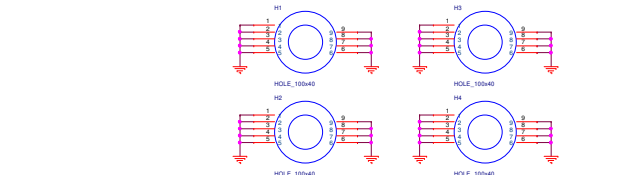
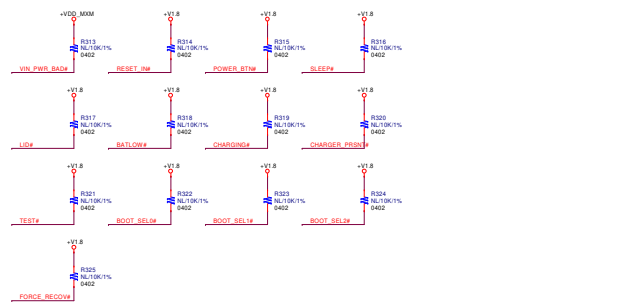
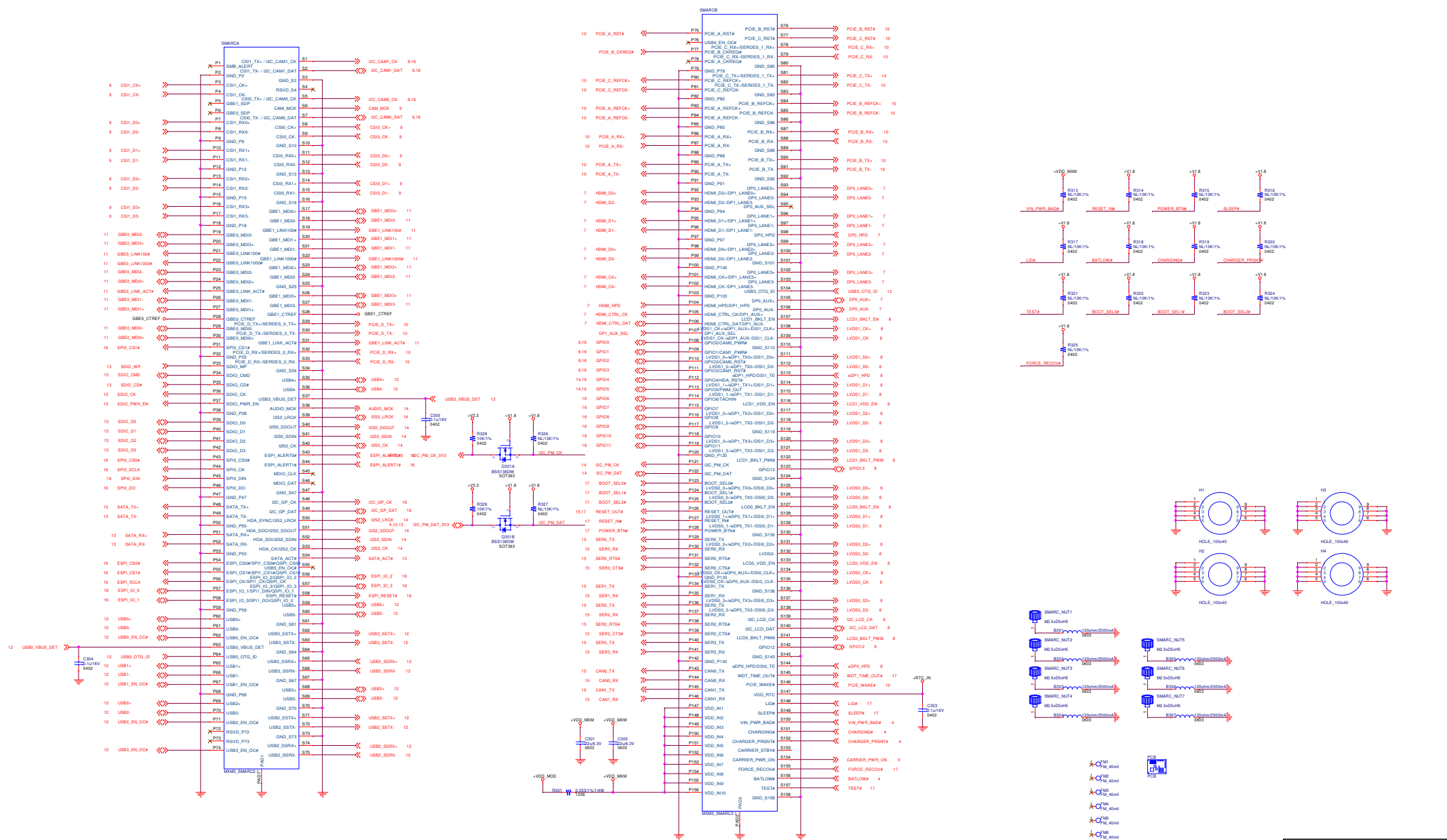

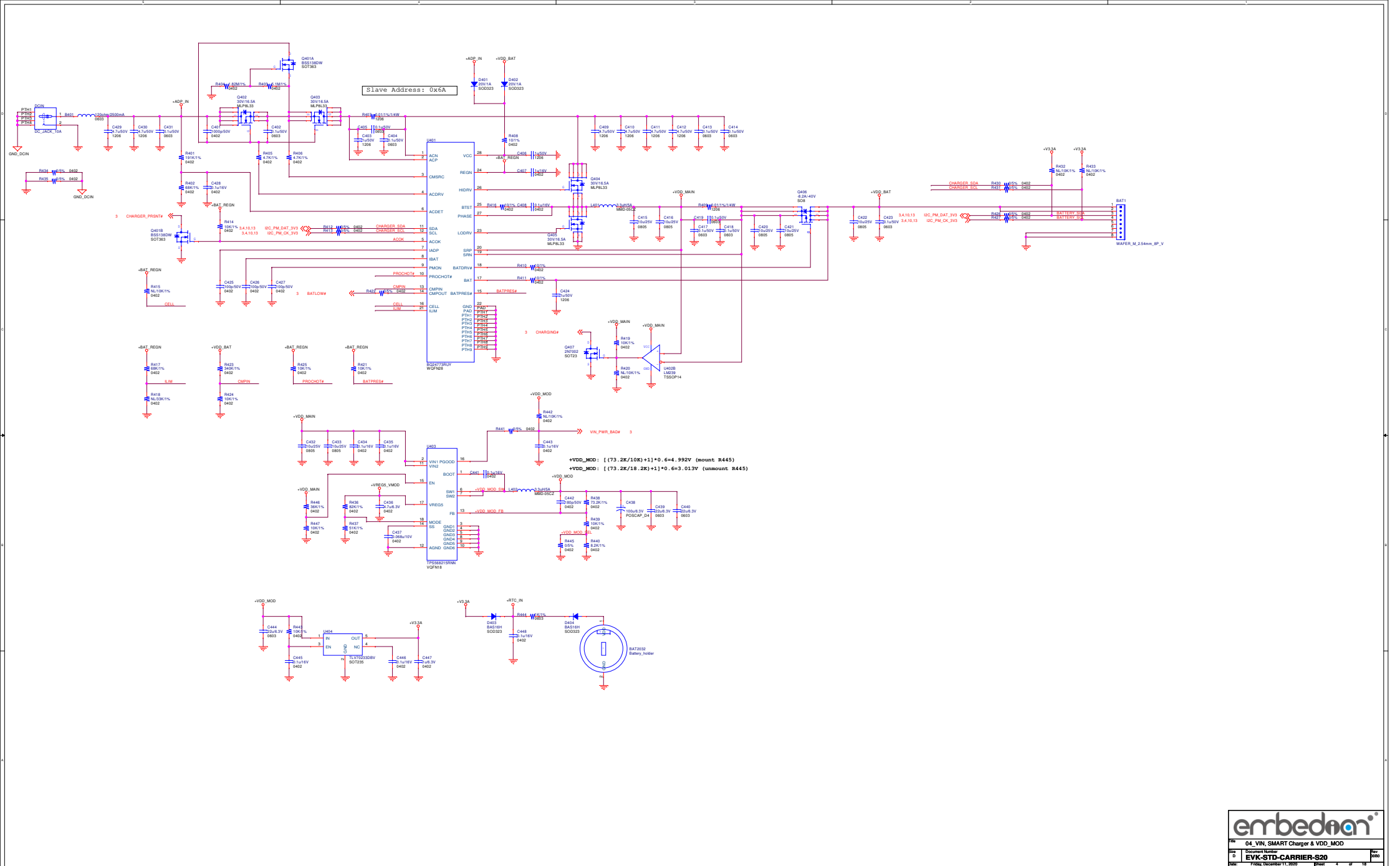

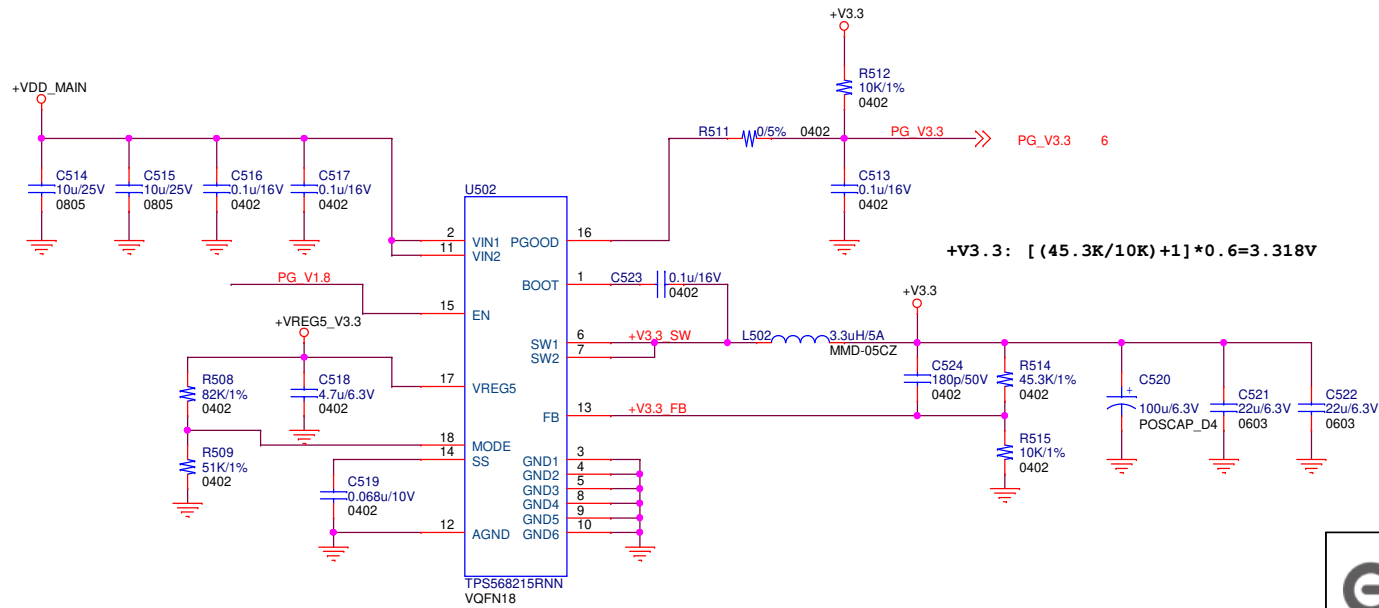
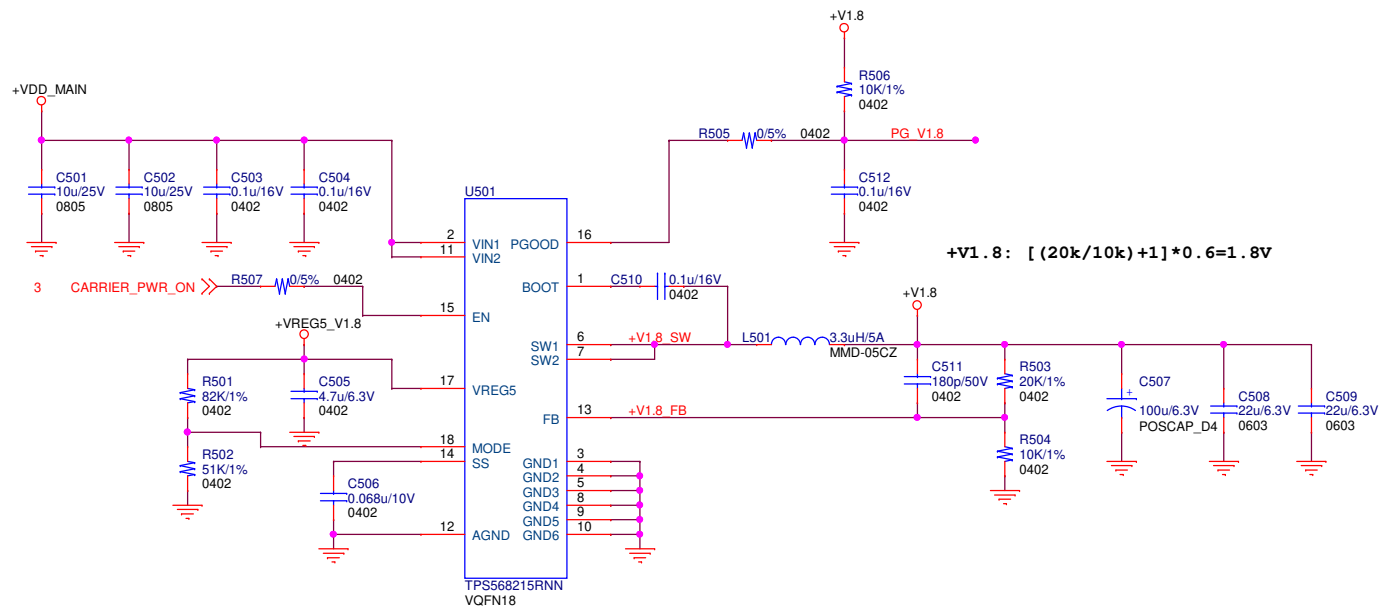

Title		05_+V1.8, +V3.3
Size	Document Number	Rev
B	EVK-STD-CARRIER-S20	00B0
Date:	Friday, December 11, 2020	Sheet 5 of 18

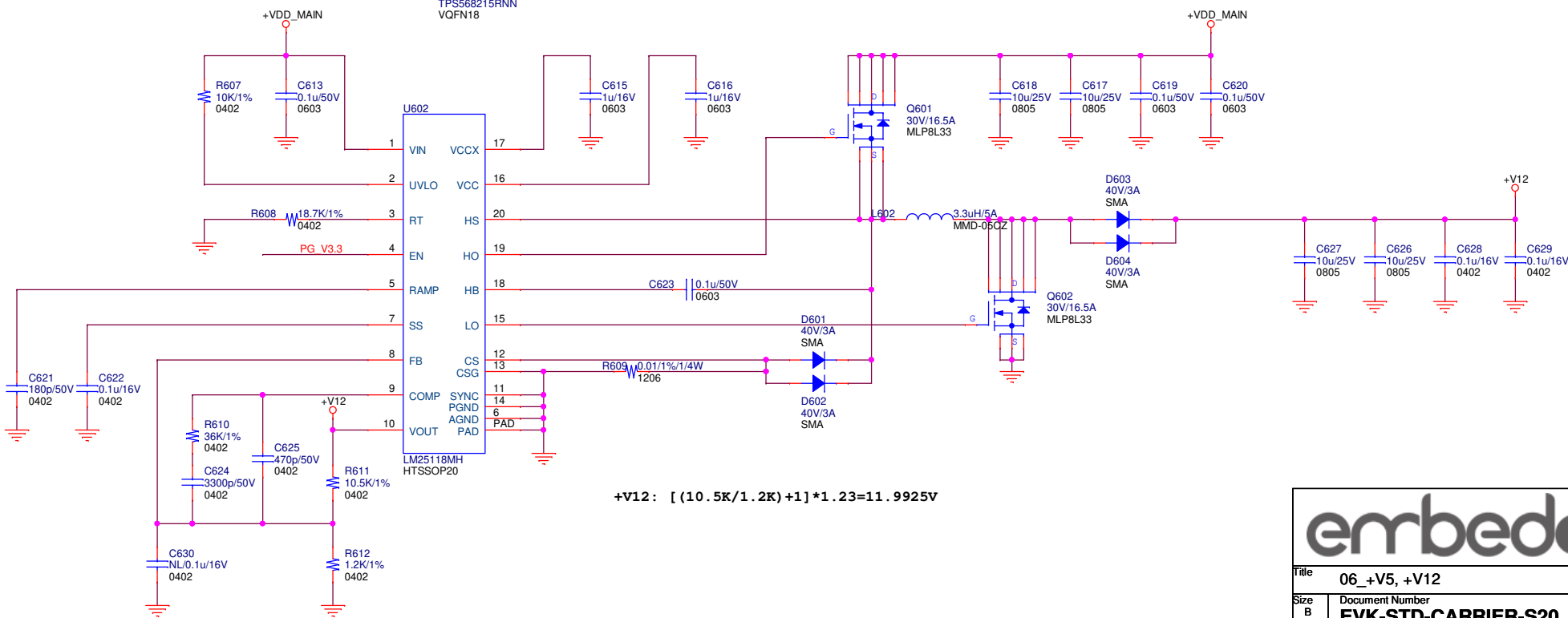
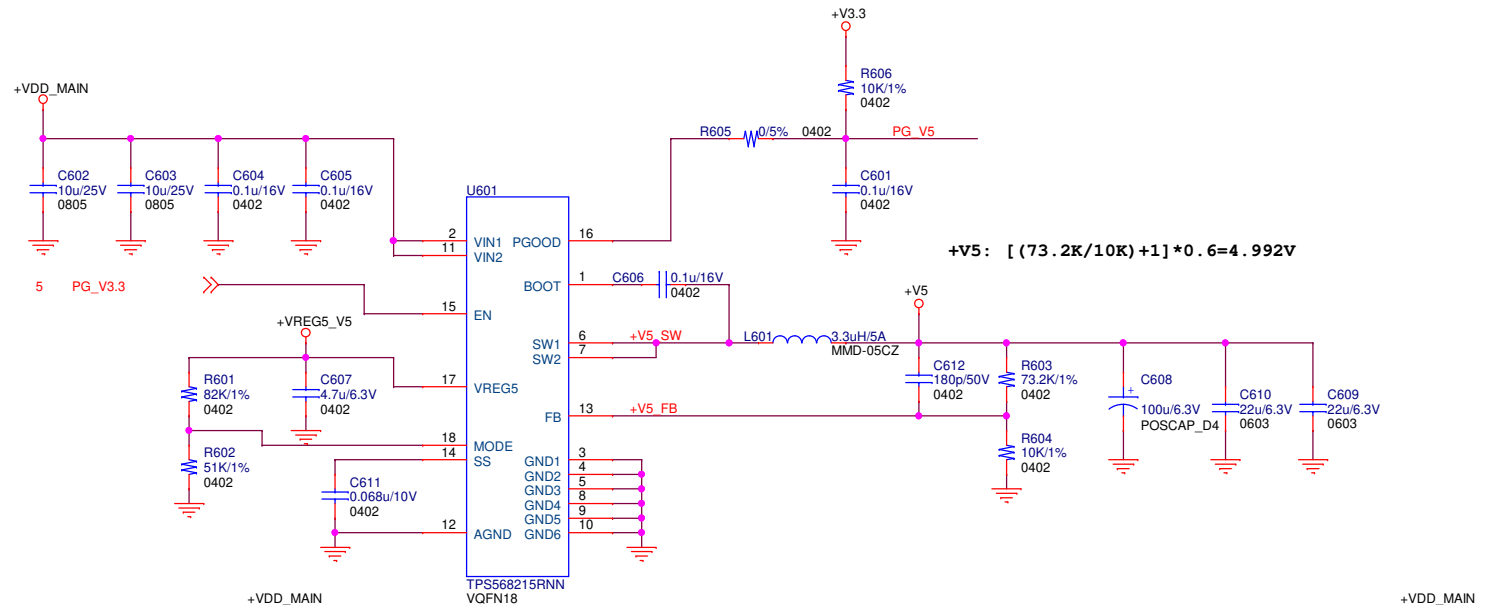

embedan

Title: **06_+V5, +V12**

Size: B

Document Number: **EVK-STD-CARRIER-S20**

Date: Friday, December 11, 2020

Sheet: 6 of 18

Rev: 0080

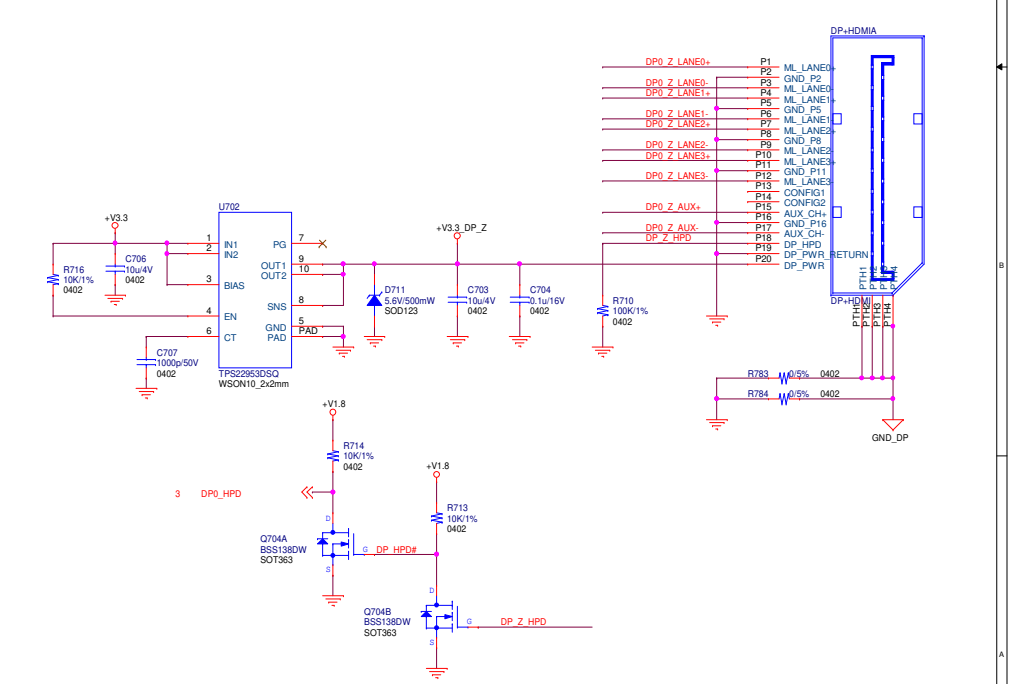
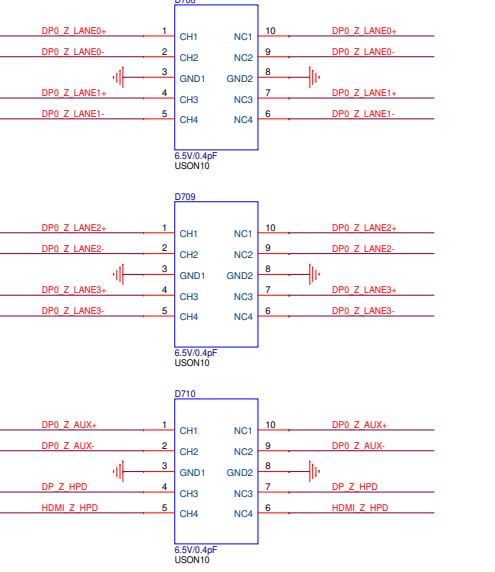
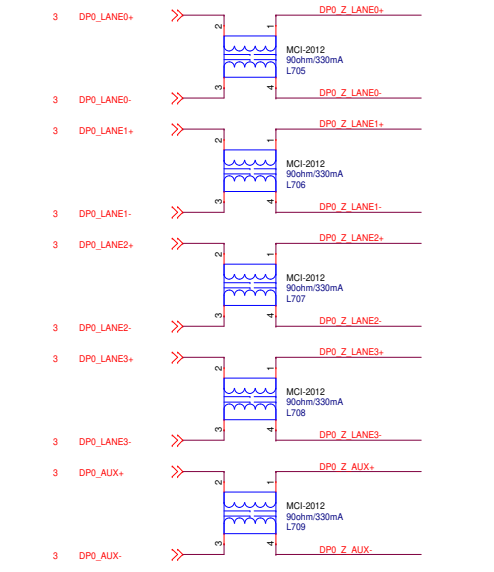
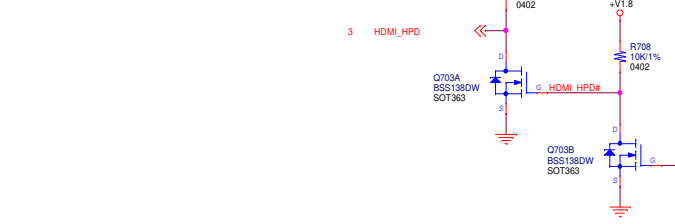
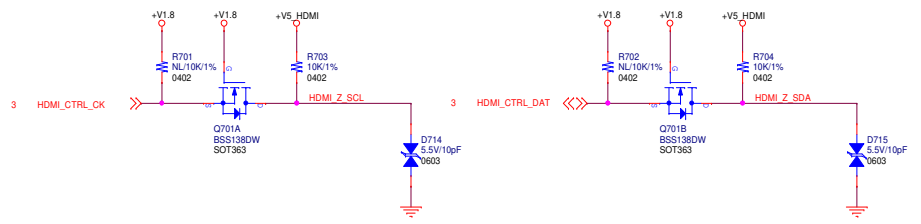
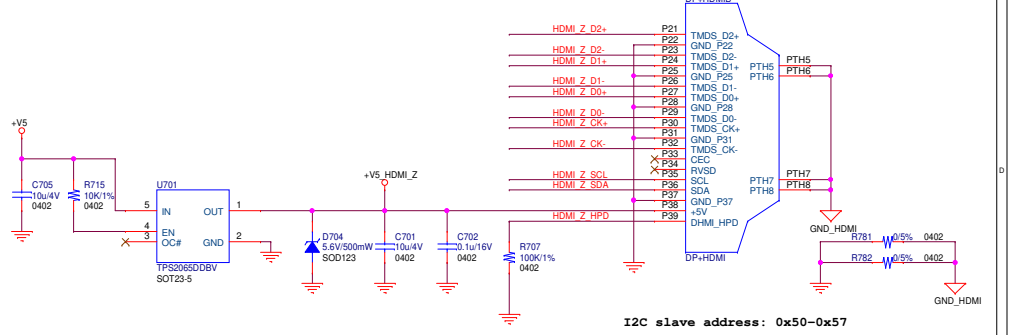
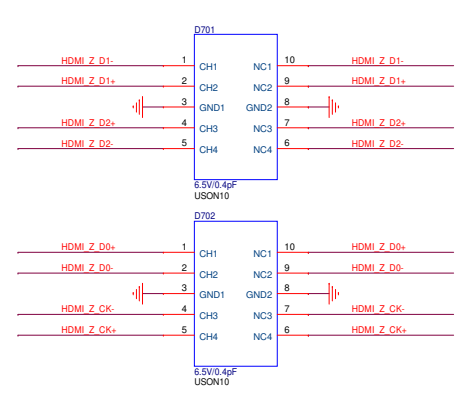
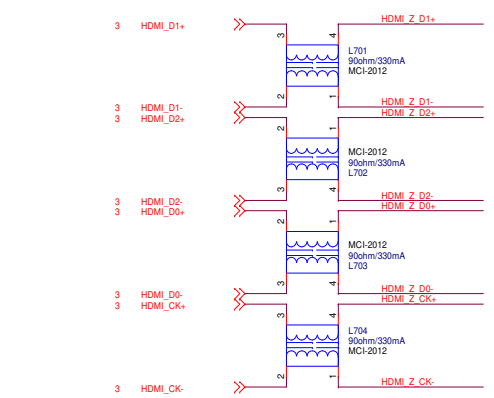

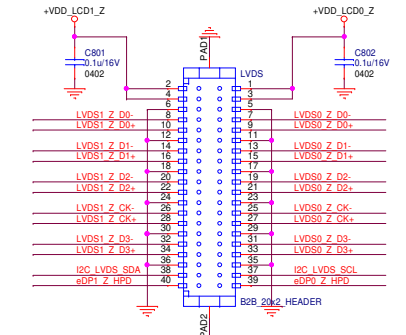
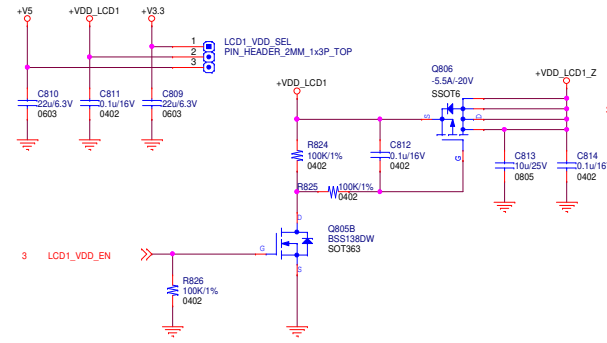
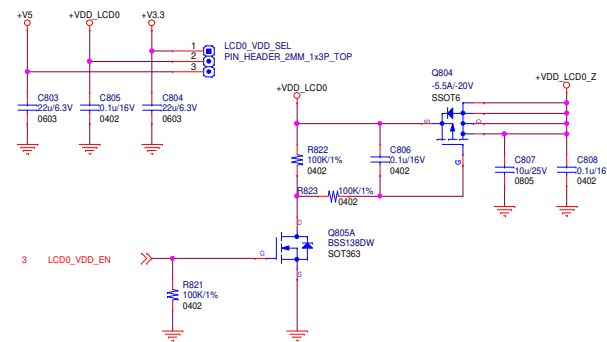
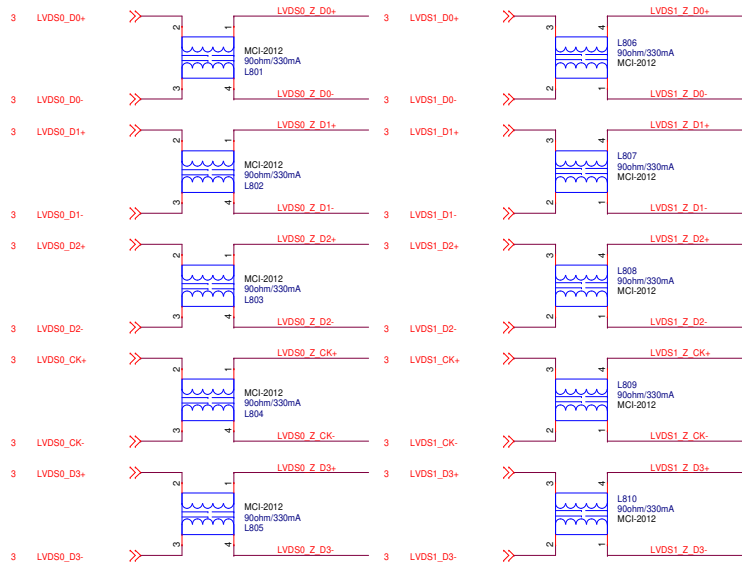

I2C slave address: 0x50-0x57

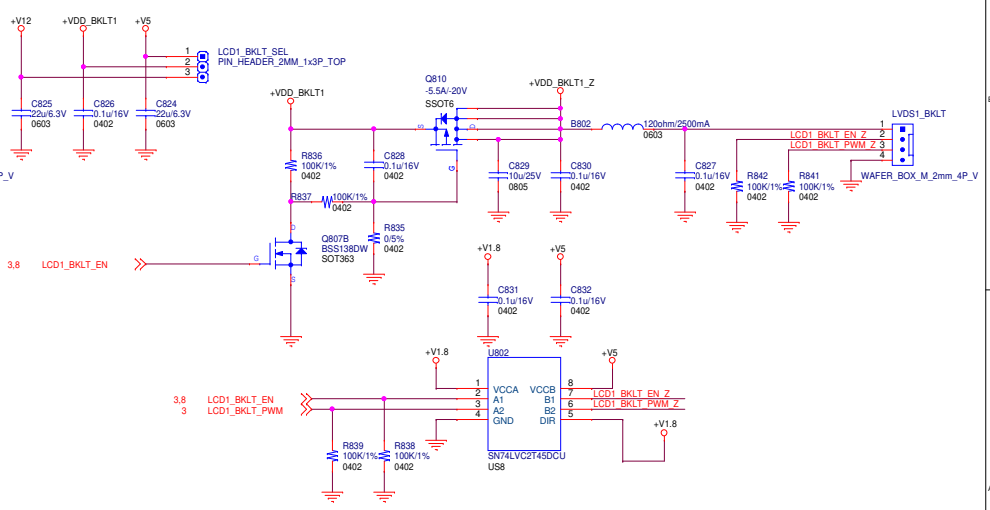
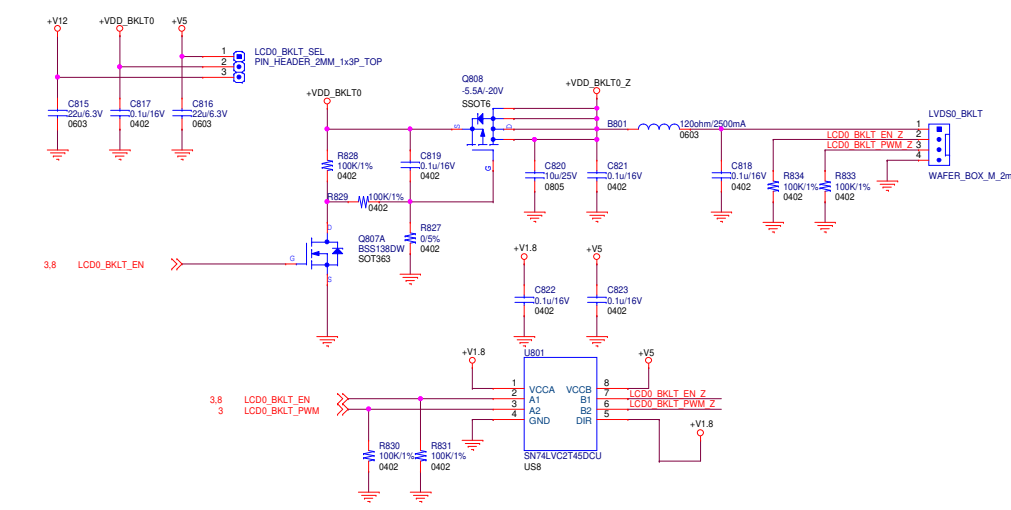
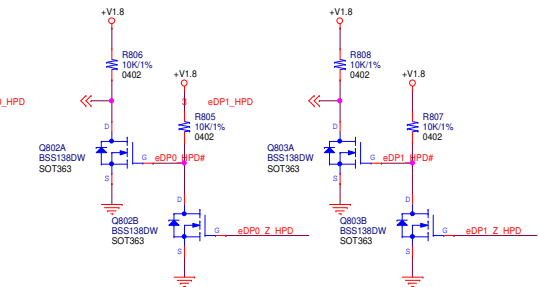
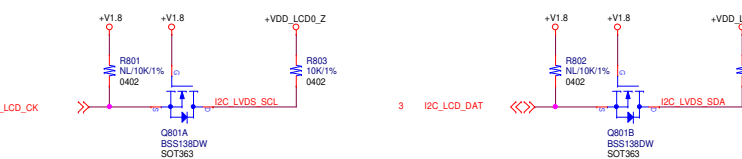

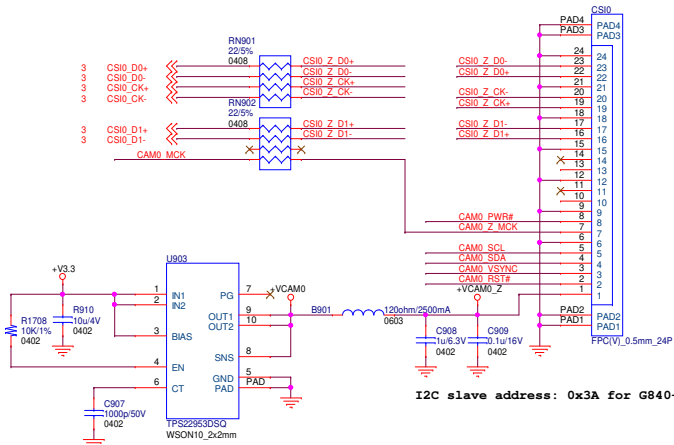
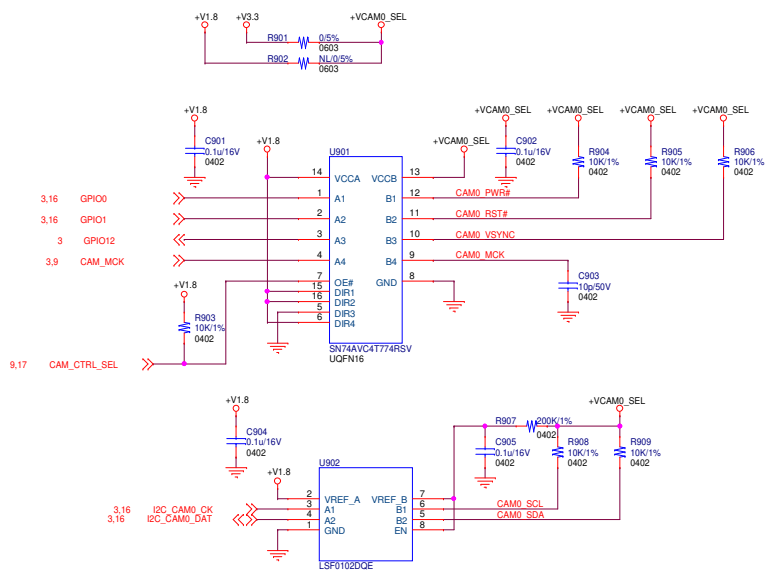

I2C slave address: 0x3A for G840-00180-01

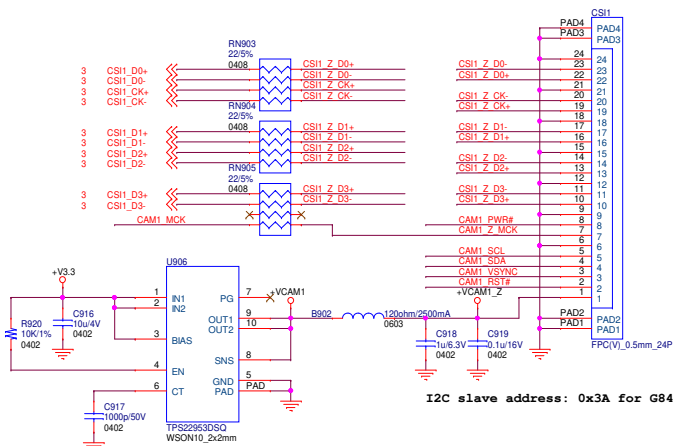
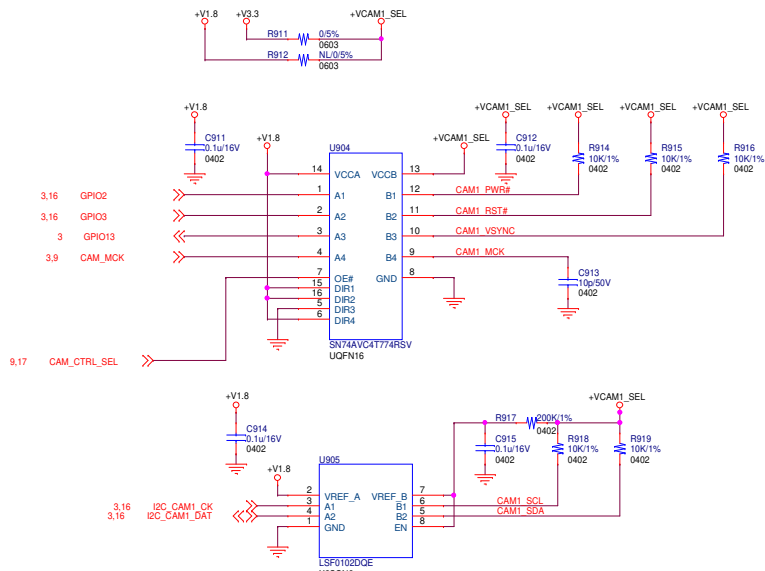

I2C slave address: 0x3A for G840-00180-01

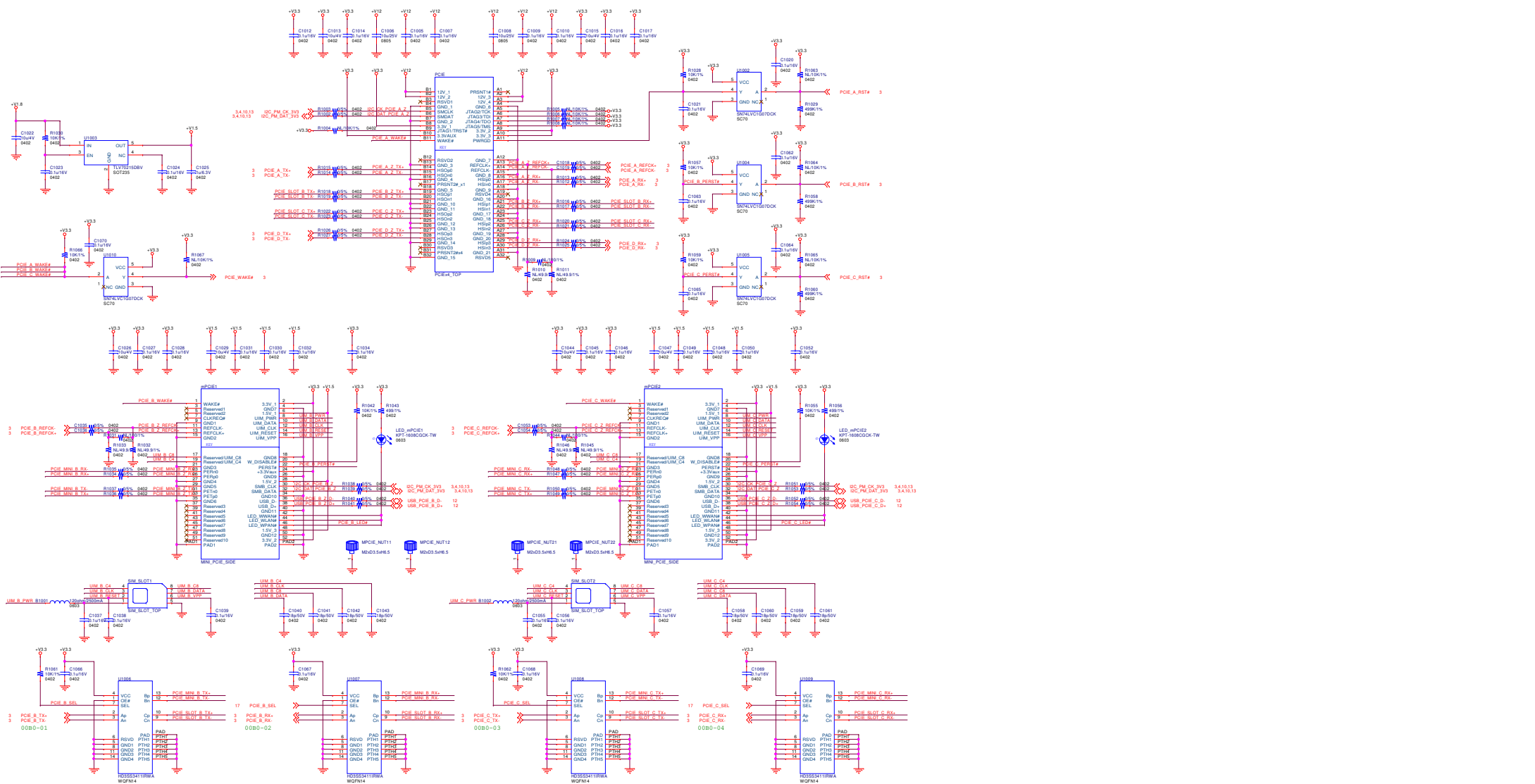

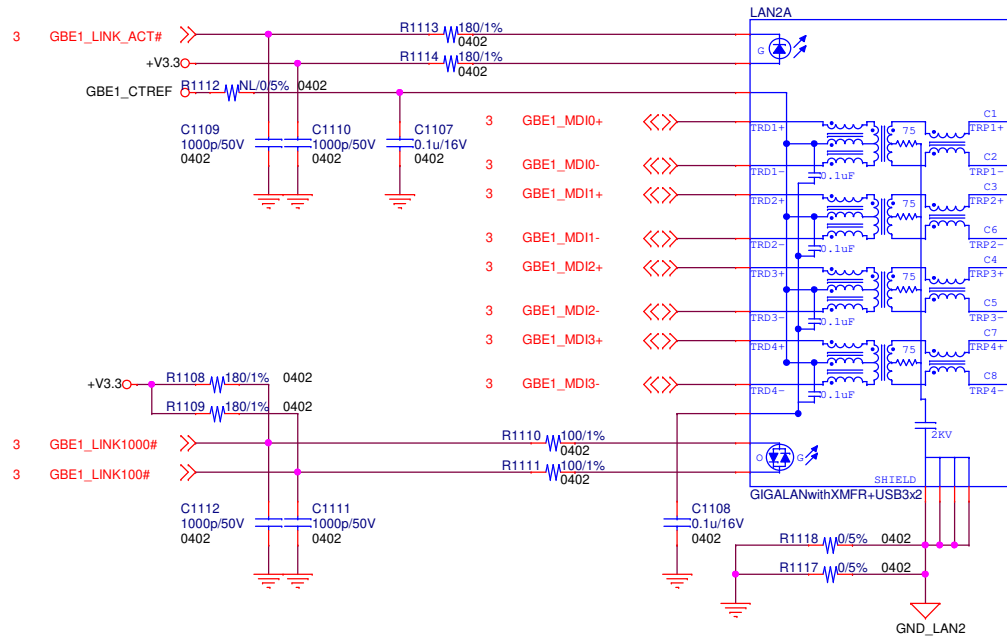
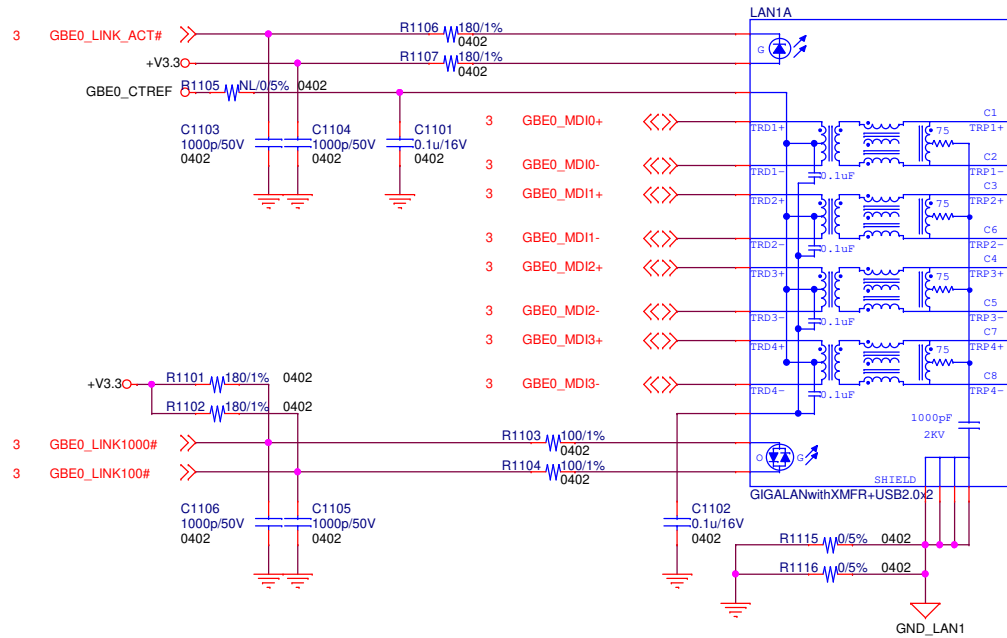

embedan

Title		11_LAN
Size	Document Number	Rev
B	EVK-STD-CARRIER-S20	00B0
Date:	Friday, December 11, 2020	Sheet 11 of 18

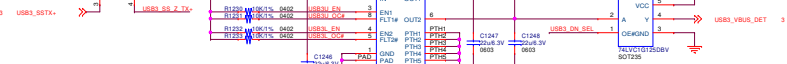
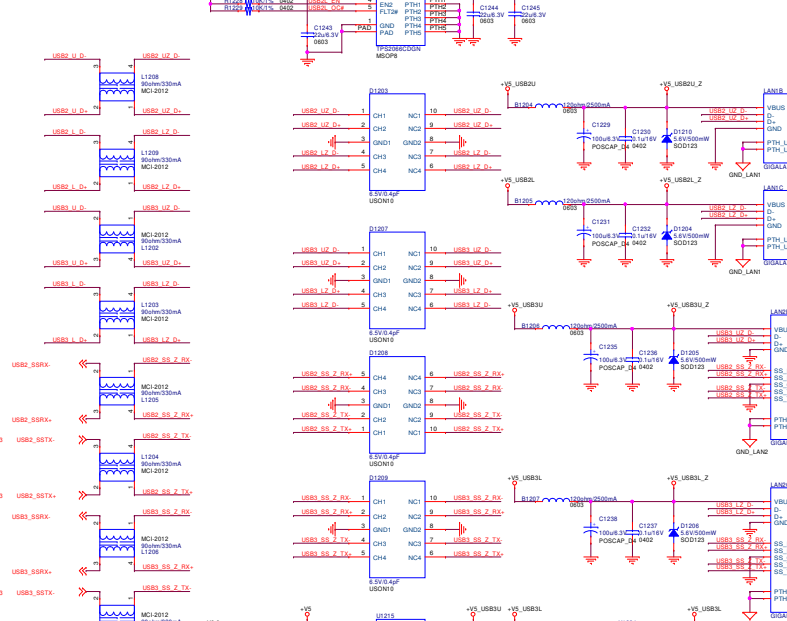
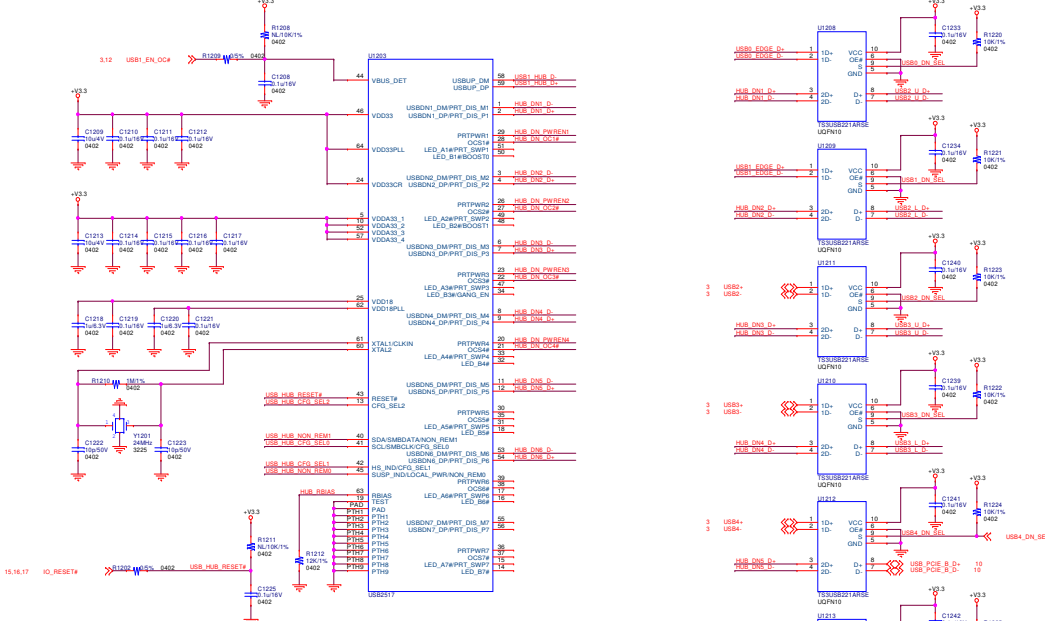
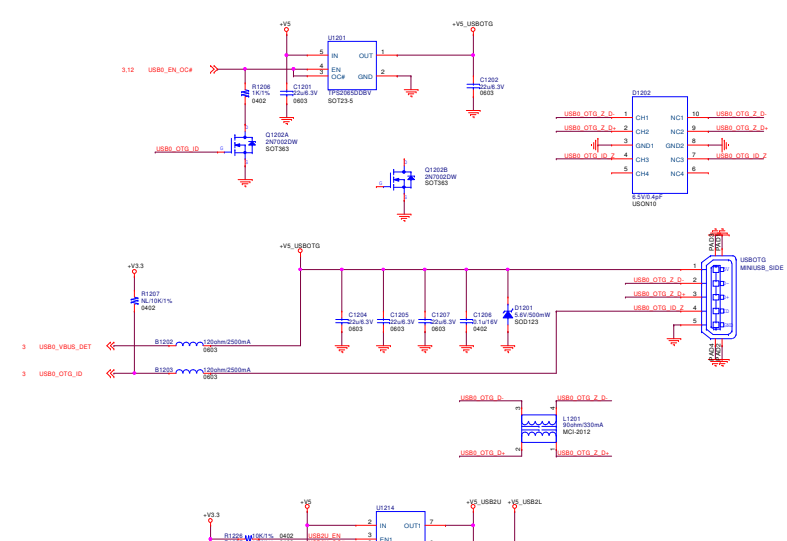
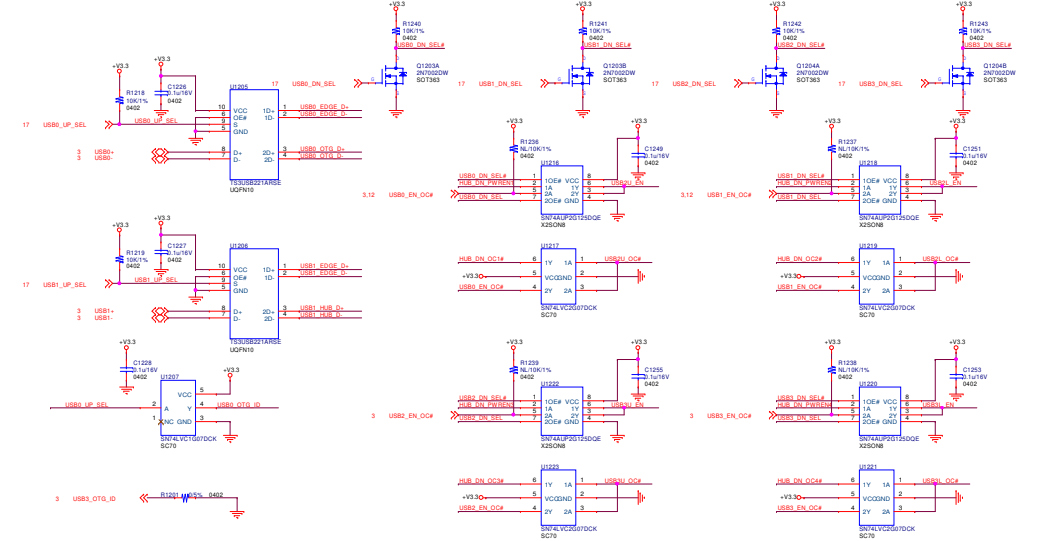

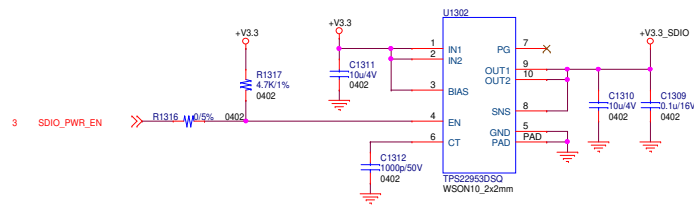
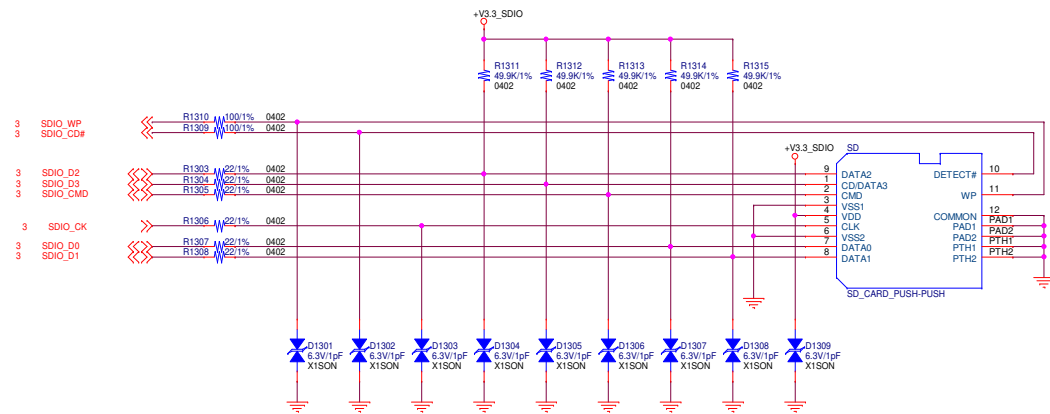
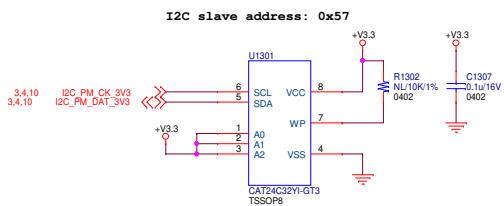
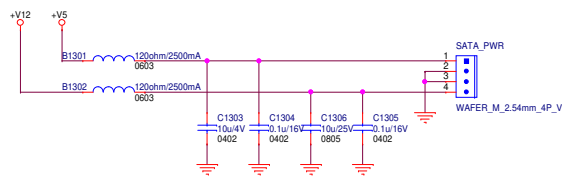
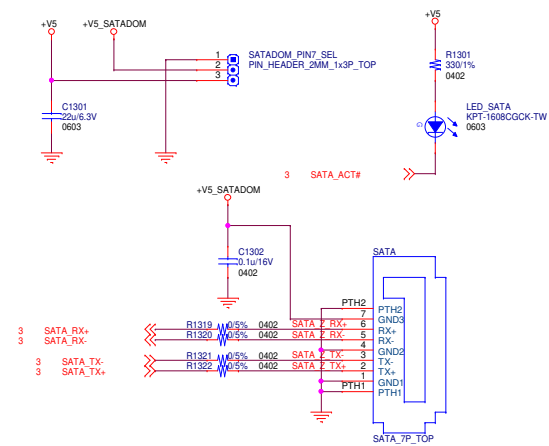

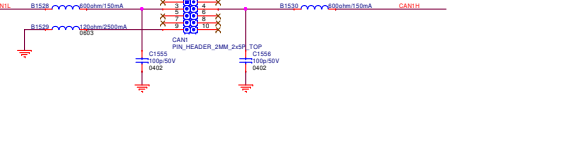
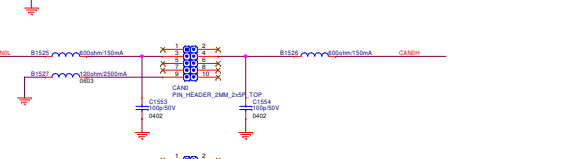
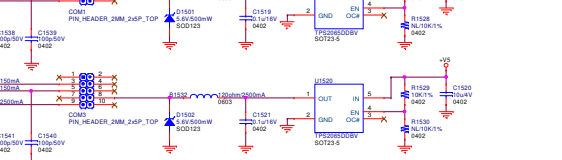
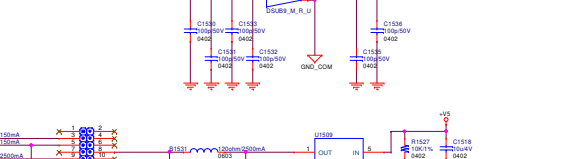
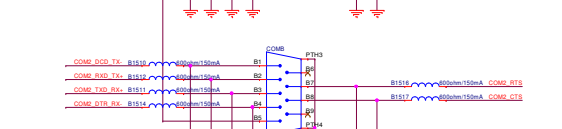
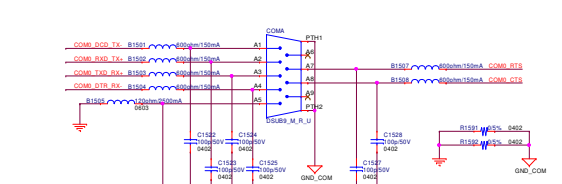
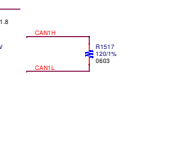
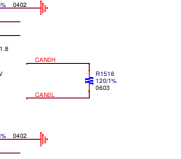
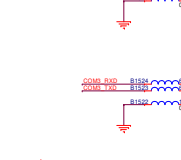
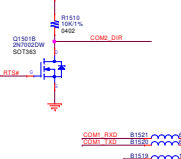
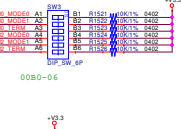
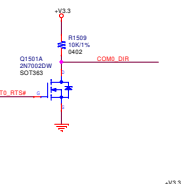
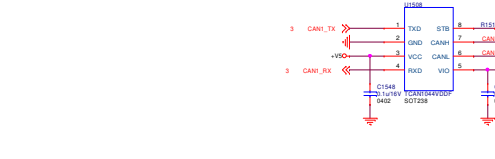
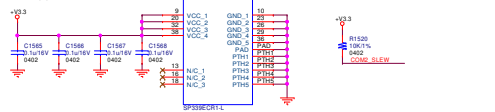
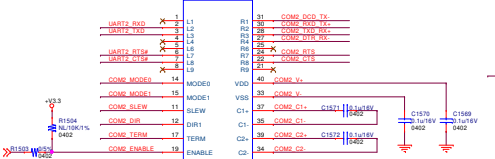
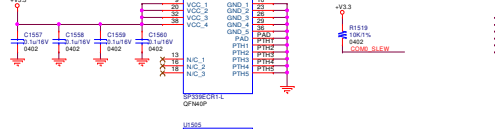
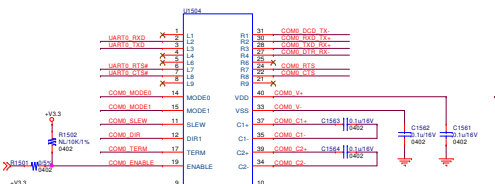
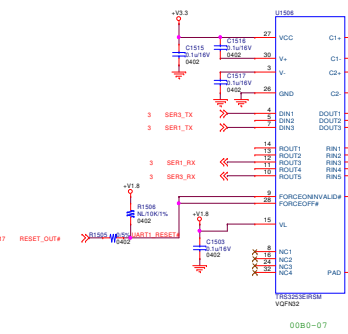
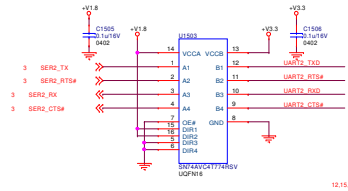
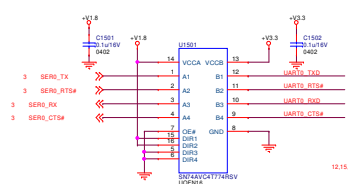

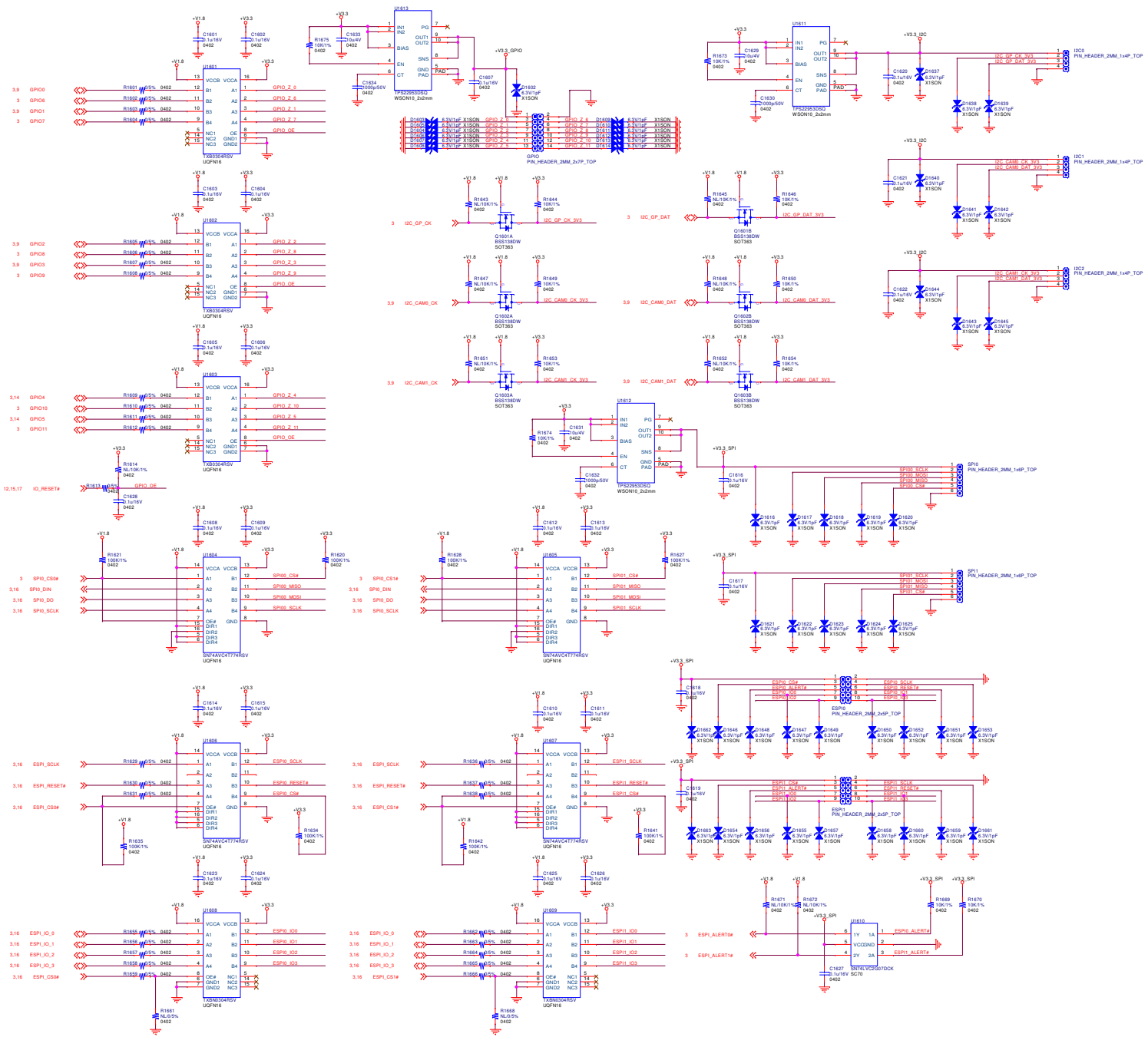

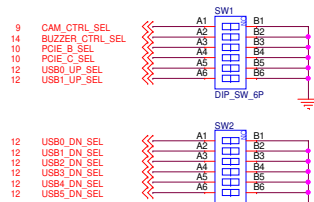
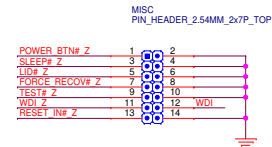
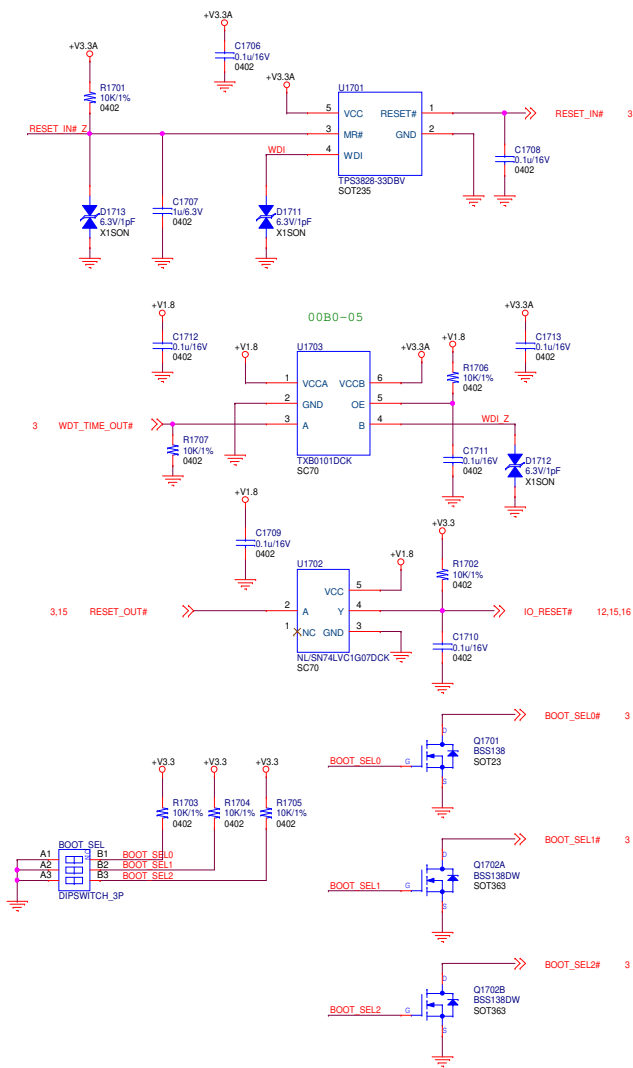
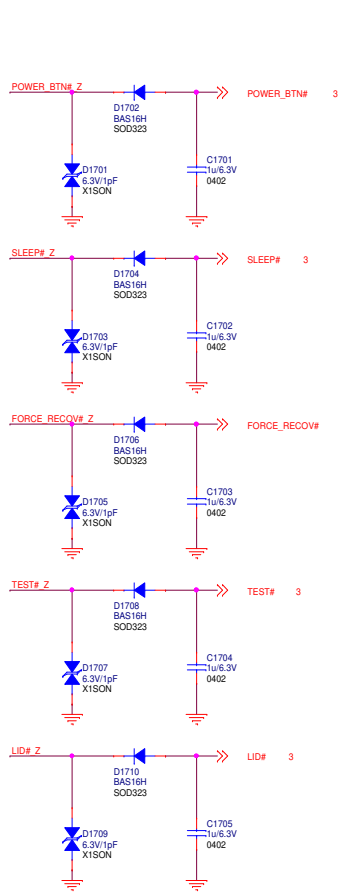

00B0:
2020/12/11_ECO: PCIE_x_REFCK+/- route to connector directly.
C1018, C1019, C1035, C1036, C1053, C1054 change to 0ohm resistors.
Unmount R1010, R1011, R1032, R1033, R1045, R1046.



Title		
18_HISTORY		
Size	Document Number	Rev
C	EVK-STD-CARRIER-S20	00B0
Date:	Friday, December 11, 2020	Sheet 18 of 18